

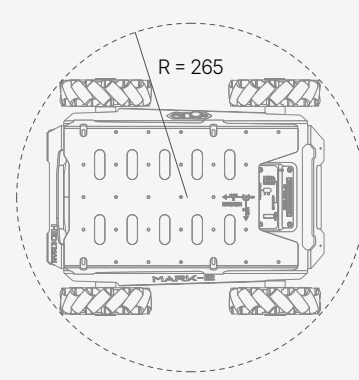

Mark, York & Neos

Model	Mark 1 Diff	Mark 1 MCNM	Mark 2 MCNM
Dimensions L x W x H	584 × 617 × 233 mm	584 × 532 × 231 mm	426 × 365 × 163 mm
Turning radius	415 mm	378 mm	265 mm
Ground clearance	132 mm	132 mm	62 mm
Weight	22 kg	22 kg	6.5 kg
Payload	25 kg	25 kg	10 kg
Speed	2 m/s	3 m/s	1.5 m/s
Max slope	40° (unloaded) / 15° (loaded)	10°	10°
Max obstacle height (unloaded)	90 mm	30 mm	25 mm
Suspension	Double wishbone	Double wishbone	Front wishbone
Runtime [1]	3 – 5 h	3 – 5 h	3 – 5 h
Motors	4 × 250 W	4 × 90 W	4 × 11 W (brushed)
Encoder	4096	1024	550
Batteries	24 V / 14.4 Ah	24 V / 10 Ah	24 V / 5 Ah
Time to charge	6 h	5 h	3 h
Interface	CAN	CAN	CAN
Ingress protection	IP22	IP22	IP22
Operating temperature	0 °C to 40 °C	0 °C to 40 °C	0 °C to 40 °C

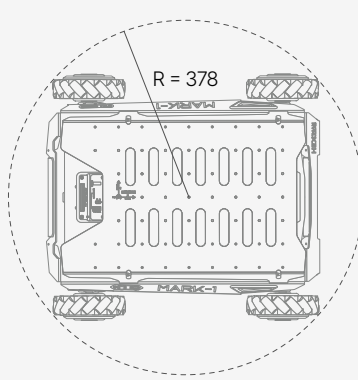
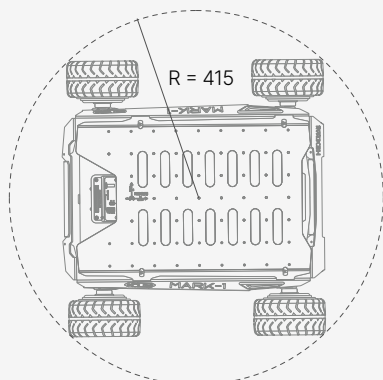
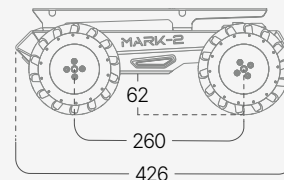
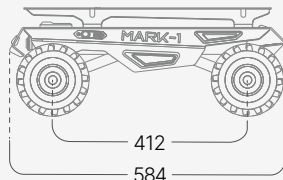
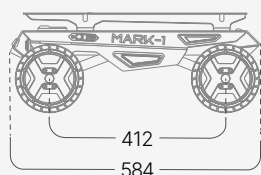
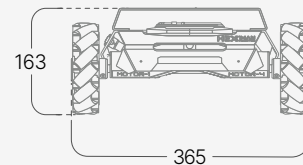
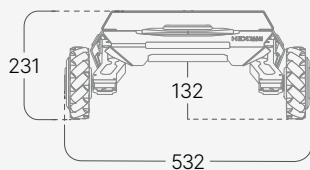
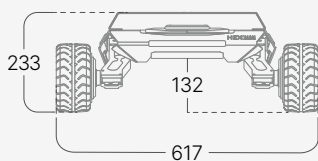
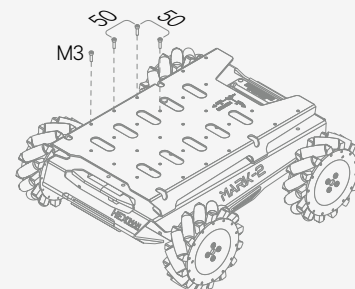
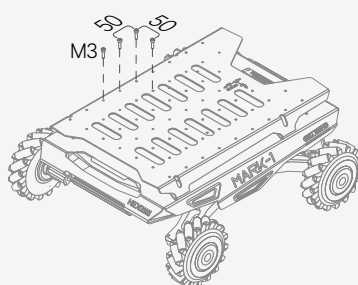
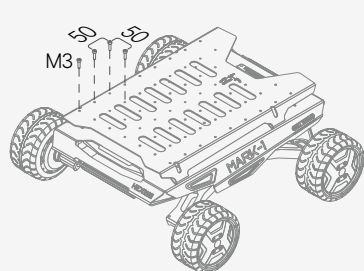

Mark



The Mark series has been developed for research and education. Its design allows for customising wheelbase and axle spacing and choosing between a variety of motion modes. Mark can be easily equipped with lidar, camera, GPS, 4G or 5G, a robotic arm and other modules.

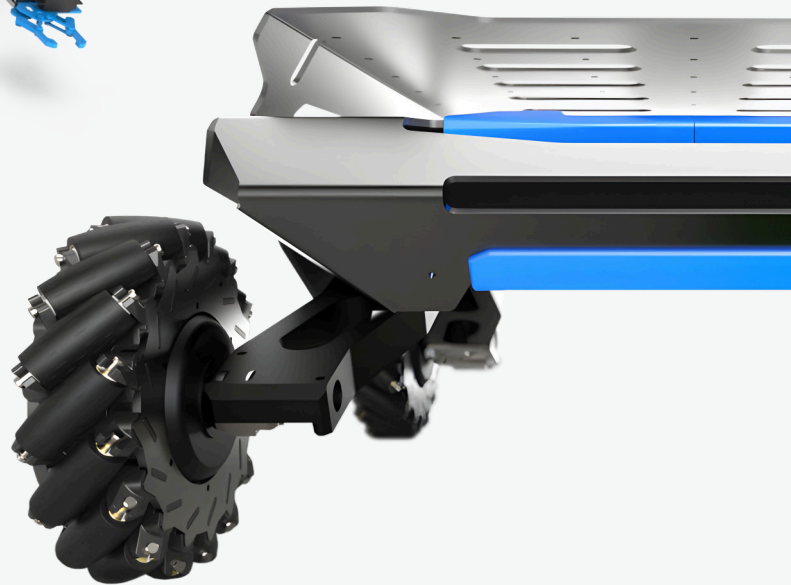

York



York is a multi-purpose chassis with Mecanum, Ackermann or differential 4-wheel steering, making it adaptable to a wide range of indoor and outdoor environments. Its compact size and handle make it easy to carry around. Turn the page for more details.

Neos

Neos is a universal mobile robotic chassis capable of carrying up to 50 kg of payload. With Ackermann steering, Neos achieves speeds of up to 20 km/h and is suitable for a wide range of indoor and outdoor applications including gravel and asphalt roads. It overcomes slopes of up to 10° and bumps.

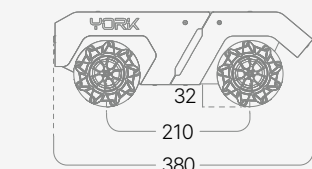
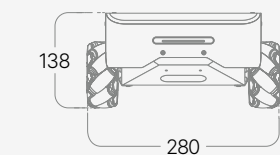
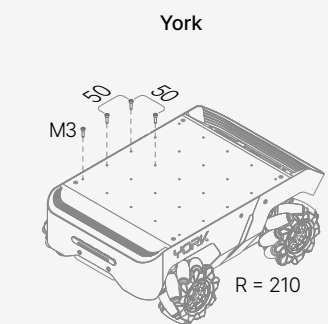
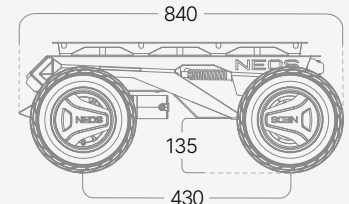
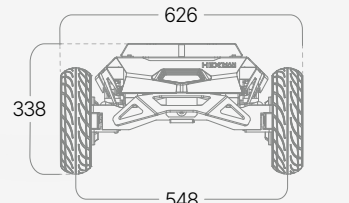
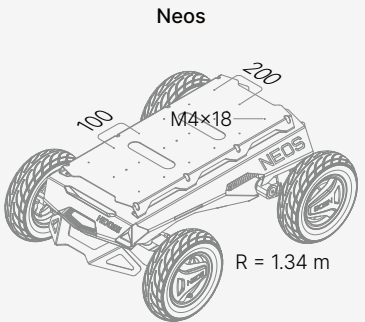

Model	York Diff	York MCNM	Neos
Dimensions L x W x H	380 × 268 × 140 mm	380 × 280 × 138 mm	840 × 626 × 338 mm
Turning radius	210 mm	210 mm	1.34 m
Ground clearance	34 mm	32 mm	135 mm
Weight	3.5 kg	3.5 kg	47 kg
Payload	3 kg	4 kg	50 kg (10°) / 80 kg (5°)
Speed	0.5 m/s	0.5 m/s	20 km/h
Max slope	10°	10°	10°
Max obstacle height	10 mm (unloaded)	10 mm (unloaded)	100 mm (unloaded)
Steering	Four-wheel diff.	Mecanum	Ackermann
Runtime [1]	3 – 5 h	3 – 5 h	5 – 8 h
Motors	4 × 11 W	4 × 11 W	2 × 350 W
Encoder	990	990	4096
Batteries	24 V / 5 Ah	24 V / 5 Ah	48 V / 15 Ah
Time to charge	3 h	3 h	3.5 h
Interface	CAN	CAN	CAN (USB optional)
Ingress protection	IP22	IP22	IP42 (IP65 optional)
Operating temp.	0 °C to 40 °C	0 °C to 40 °C	0 °C to 40 °C

[1] The runtime is strongly influenced by the working conditions. Errors and technical modification subject to change.

Contact us

office@general-laser.at

general-laser.at